



Reg. No. :

--	--	--	--	--	--	--	--	--	--	--	--	--	--	--	--	--	--	--	--	--

Question Paper Code : 90279

B.E./B.Tech. DEGREE EXAMINATIONS, NOVEMBER/DECEMBER 2019
First Semester
Civil Engineering
GE 8152 – ENGINEERING GRAPHICS
(Common to all branches)
(Regulations 2017)

Time : Three Hours

Maximum : 100 Marks

Answer ALL questions.

(5×20=100 Marks)

1. a) A fixed point is 50 mm from a fixed line. Draw the locus of a point moving in such a way that its distance from the fixed straight line is equal to its distance from the fixed point. Name the curve and draw a tangent and a normal at a point horizontal distance of 40 mm from the directrix. (20)

(OR)

- b) The pictorial view of an object is shown in Fig. 1. Draw the following views : (20)
- i) Elevation in the direction of arrow.
 - ii) Top View and
 - iii) Left Side View.

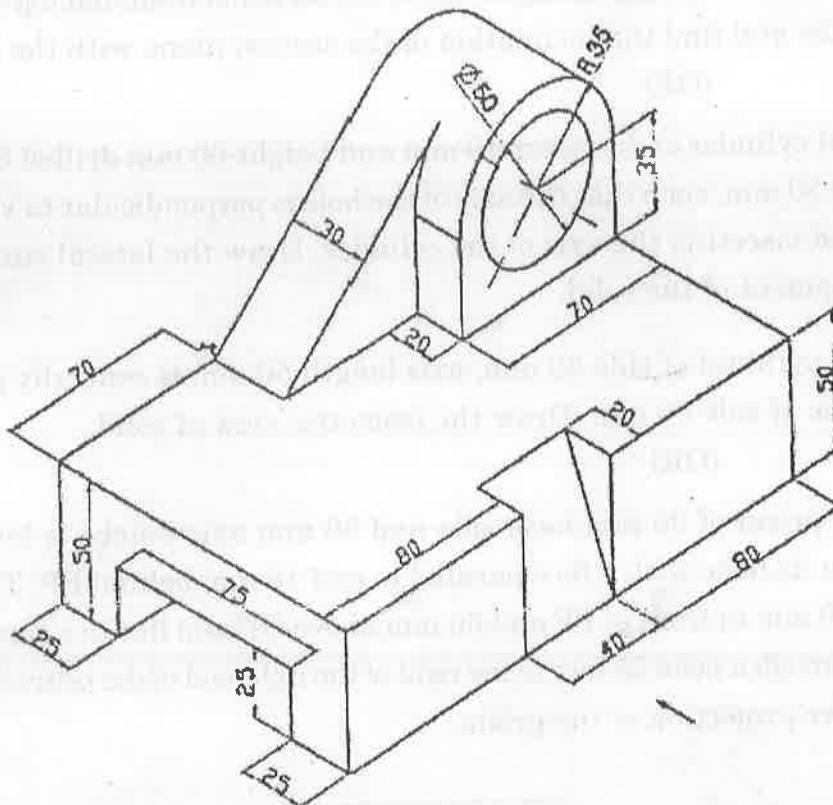

Fig. 1



2. a) A line PQ is inclined at 35° to VP has its ends 25 mm and 55 mm above the HP. The length of the front view is 60 mm and its VT is 15 mm above HP. Determine the true length of PQ, its inclination with HP and its HT. (20)
- (OR)
- b) A regular hexagon lamina of 25 mm side has its one of its edge on HP. The surface of the lamina is perpendicular to VP and inclined at 40° to HP. Draw the three views of the plane and locate the traces. (20)
3. a) A pentagonal pyramid of base side 25 mm and height 60 mm is resting on its base in HP with its axis perpendicular to HP and one of the base edges perpendicular to VP lying on its left. Draw its front view, top and right side views. (20)
- (OR)
- b) Draw the projections of a cone base 30 mm and axis 50 mm long resting on a point of its base circle in HP with the axis making an angle of 45° with HP and parallel to VP. (20)
4. a) A cube of side 35 mm is placed and cut by a plane in such a way that the true shape of the section is a regular hexagon. Draw the sectional front and top views of the cube and find the inclination of the section plane with the HP. (20)
- (OR)
- b) A vertical cylinder of diameter 40 mm and height 60 mm drilled by a hole of diameter 30 mm, such that the axis of the hole is perpendicular to VP, parallel to HP and bisecting the axis of the cylinder. Draw the lateral surface of development of the solid. (20)
5. a) A square pyramid of side 30 mm, axis length 50 mm is centrally placed on top of cube of side 50 mm. Draw the isometric view of solid. (20)
- (OR)
- b) A square prism of 30 mm base side and 50 mm axis height is lying on the ground on its base with a face parallel to and 15 mm behind PP. The station point is 40 mm in front of PP and 60 mm above GP and lies in a central plane passing through a point 25 mm to the right of the right end of the prism. Draw the prespective projection of the prism. (20)
-